



Equalizer Systems
55169 County Road 3
P.O. Box 668
Elkhart, IN 46515
800-846-9659

Forest River Slide-Out Adjustment, Trouble Shooting, and Timing Shaft Replacement Guide

August 2008

This troubleshooting guide will outline slide-out adjustment guidelines and timing shaft replacement procedures.

Note: This guide only applies to coaches equipped with Equalizer Systems shaft timed slide-out systems.

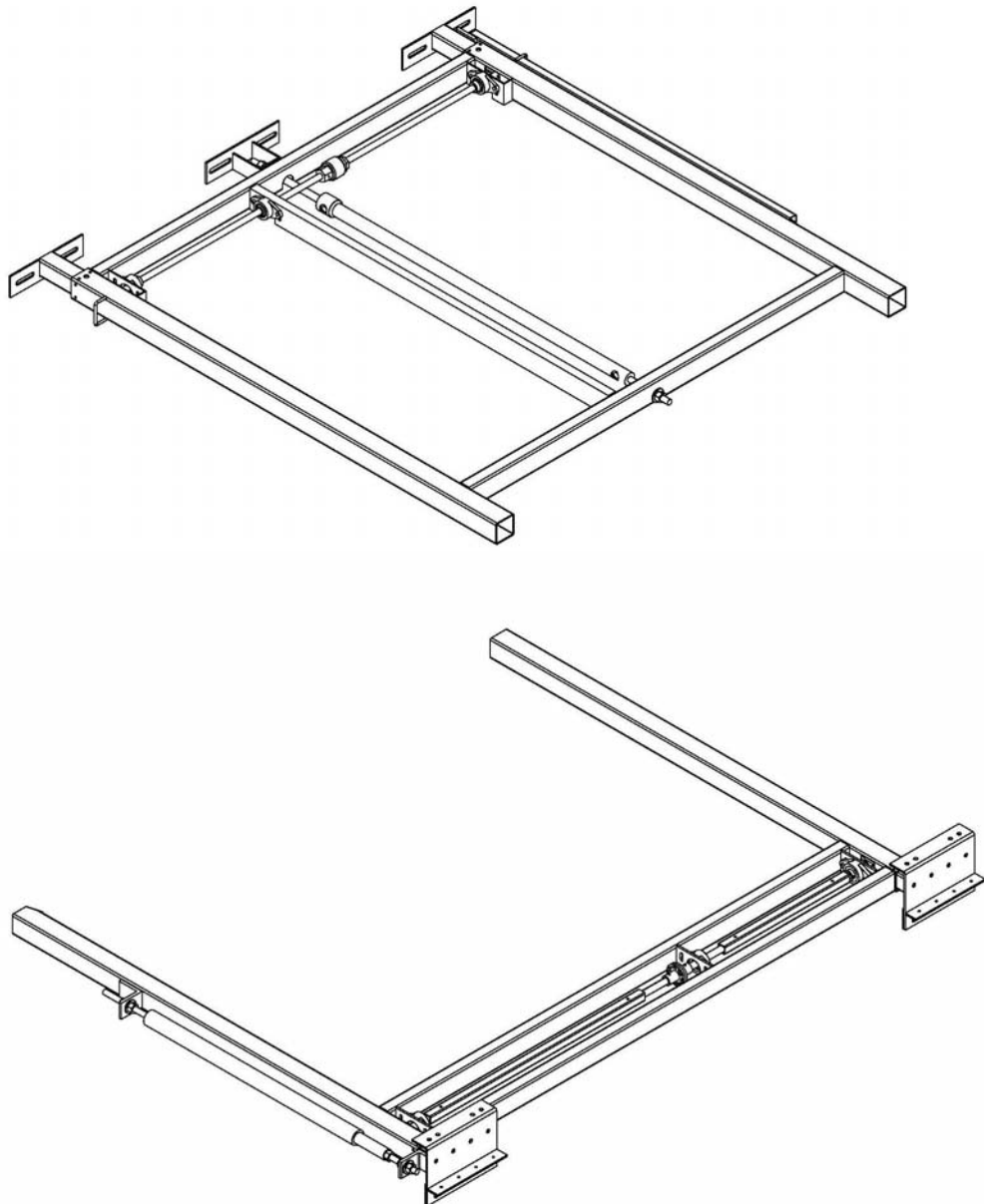

Slide Room Height Adjustment

A critical factor for slide out operation is proper room height adjustment. It is important to maintain weight on the slide out rail mechanism through the range of motion.

Non-Flat or Above Floor Slide Out:

(See Figure 1)

Dimension from bottom of slide box to top of inner rail:

$$B \geq A$$

B must be equal to or greater than A

Typically $B = A (+\frac{1}{8}'' , -0'')$

Flat or Flush Floor Slide Out:

(See Figures 2 or 3)

With the floor of the room positioned at the top of the ramp: (see figure 2)

$$B \geq A$$

B must be equal to or greater than A

Typically $B = A (+\frac{1}{8}'' , -0'')$

OR

With the floor of the room positioned at the bottom of the ramp: (see figure 3)

$B = A + \text{thickness of slide-out floor}$

Typically $B = A + \text{floor thickness} + \frac{1}{8}''$

These dimensions result in the inner rail being roughly parallel to the bottom of the slide room floor.

If the "B" dimension is less than "A", the inner rail will be lifted as the room closes. This will result in unnecessary strain on the mechanism.

The "B" dimension can be greater than "A" without causing damage or wear to the slide out system.

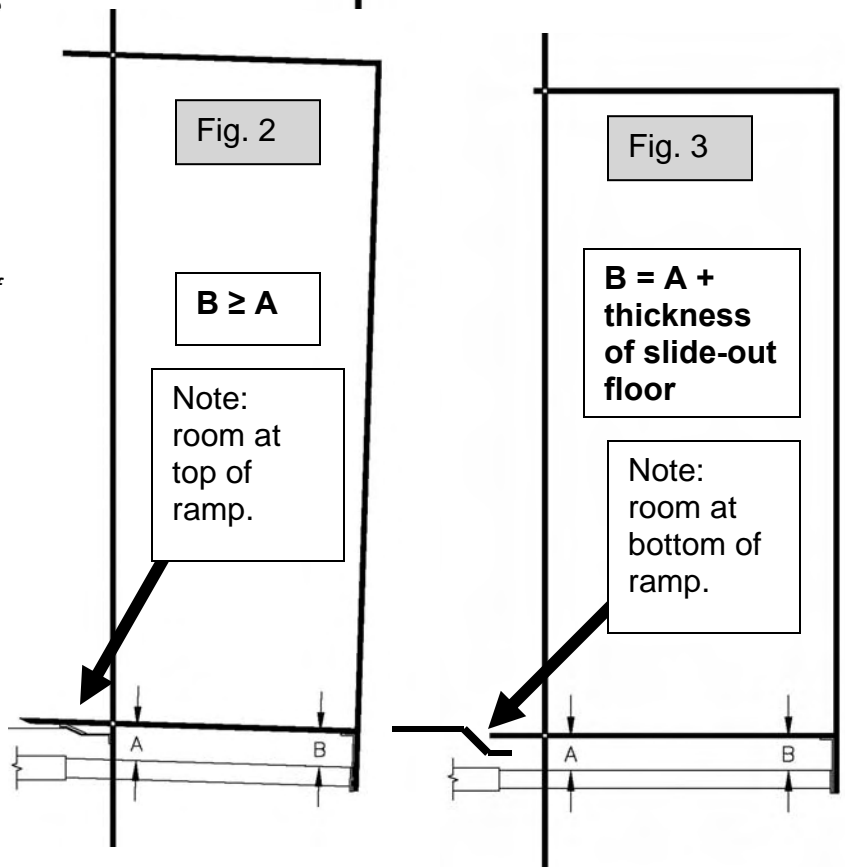
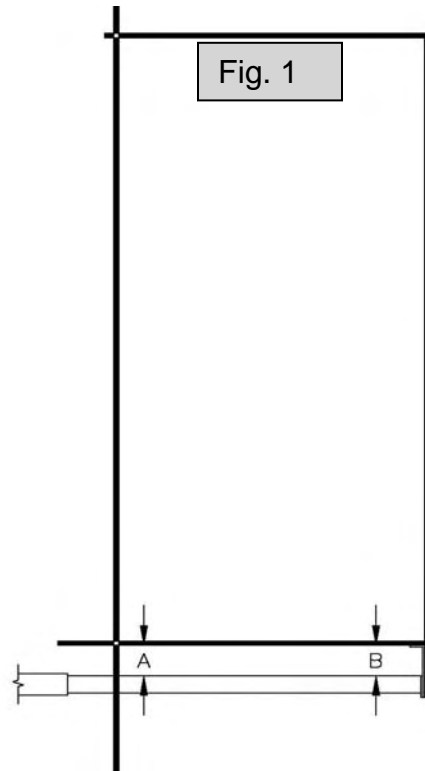

The slide-out height adjustment is made through the bolts at the end of the inner slide-out rail that fasten the room attach bracket. Both the end inner slide-out rail and the attachment bracket have slotted holes to allow vertical and horizontal adjustment.



There may not be enough vertical adjustment in the bracket to obtain the proper dimensions. It may be necessary in some cases to add shims between the connection points of the room attachment bracket and the slide room.

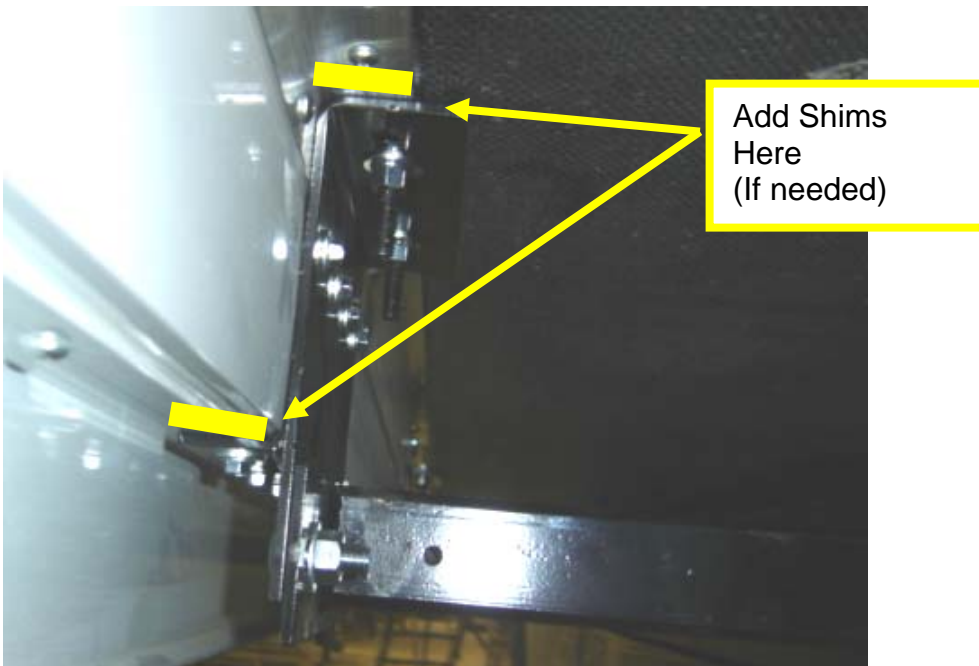

Note: Alignment of paint graphics may be affected by making this adjustment.

Additionally, note the tight envelop the room attachment brackets. They need to have adequate clearance when the system is retracted.
The alignment of the inner slide-out rail in relation to the outer rail is also critical. The inner rail must be centered in the outer and rest squarely on the bottom wear pad.

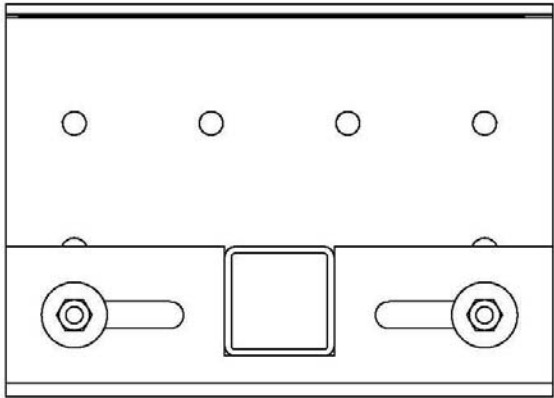

CORRECT BRACKET AND TUBE ALIGNMENT

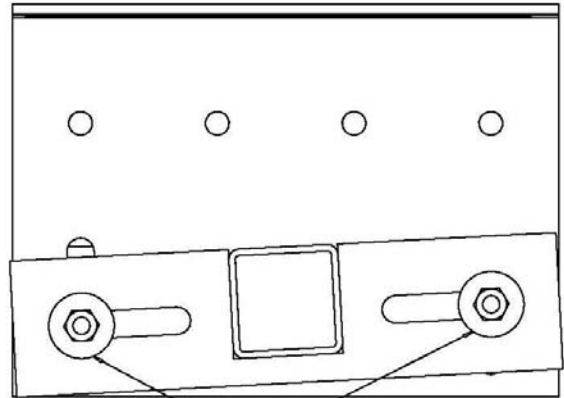

TO CORRECT THIS—LOOSEN THESE NUTS AND SQUARE UP THE BRACKETS

INCORRECT BRACKET AND TUBE ALIGNMENT



Bottom Wear Pad
Note: a portion protrudes below outer rail.

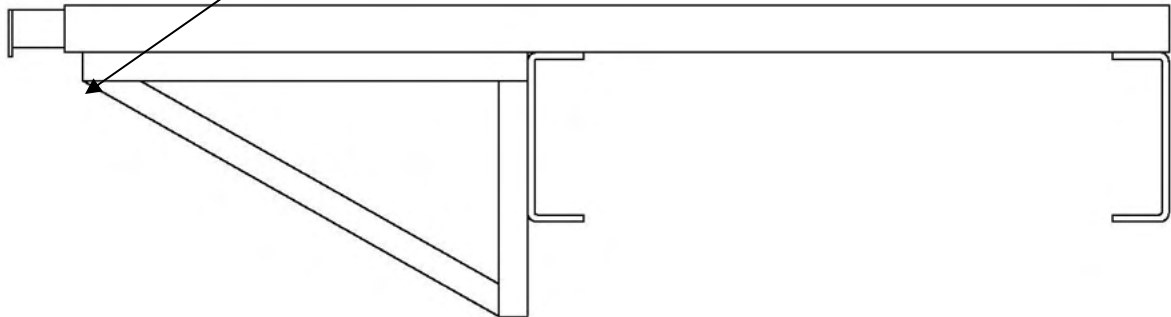
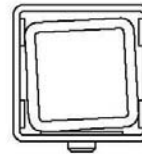

Ensure that the wear pads are allowed to protrude fully through the outer tube. Make sure that the support frame does not interfere with the wear pads from below.

Cylinder Rod Clearance- Flat/Flush Floor Systems

Another critical factor in slide-out room performance is clearance between the chrome rod of the hydraulic cylinder (that moves the room) and the timing shafts that keep the ends of the slide-out properly timed. This issue is found in flat/flush floor main room slide-outs. If the cylinder rod contacts the timing shaft and any point of room travel, it can cause deflection and bending of the timing shaft. This can result in a bent shaft and broken gears.

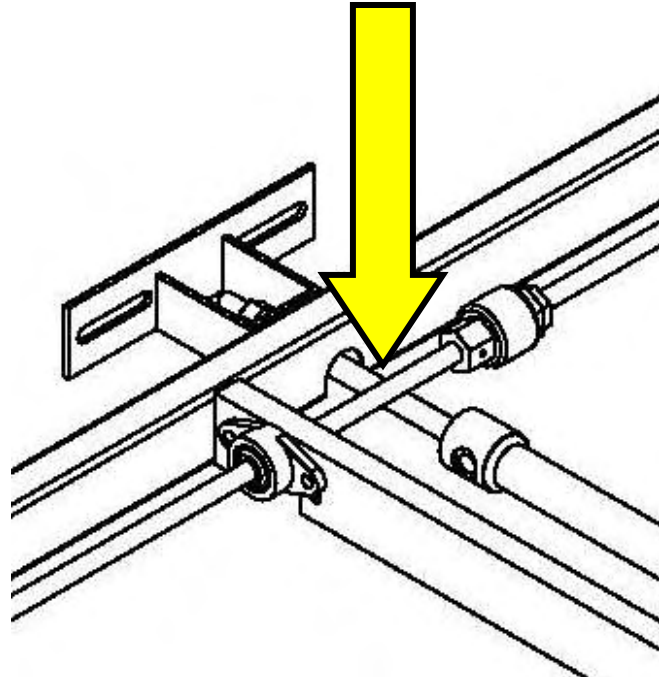

Additionally, contact between the room cylinder rod and hard surface can cause damage that could result in cylinder leakage or failure.

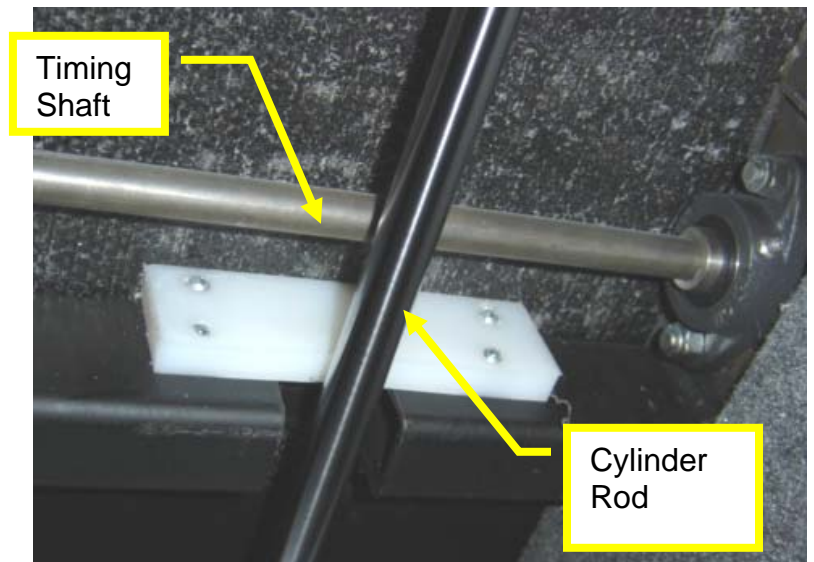

Clearance between the cylinder rod and the timing shaft results from the positioning of the cylinder room attach bracket (rod end of cylinder) and the placement of the base end of the cylinder. The space in which the cylinder must operate is also restricted by the need for the extended cylinder rod to pass through the unit's sidewall to move the slide room. Additionally, in flush floor applications, the cylinder must move slightly downward, as the room extends, to accommodate the drop of the slide room floor.

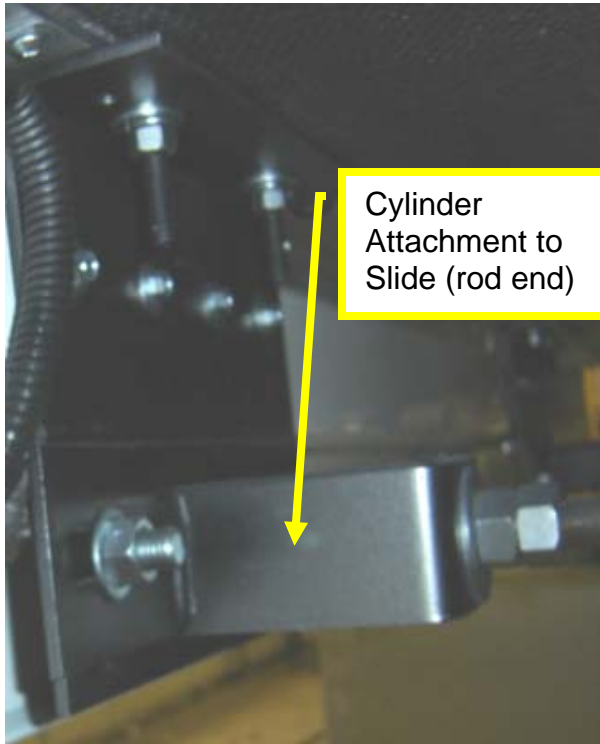

Cylinder Attachment to Slide (rod end)

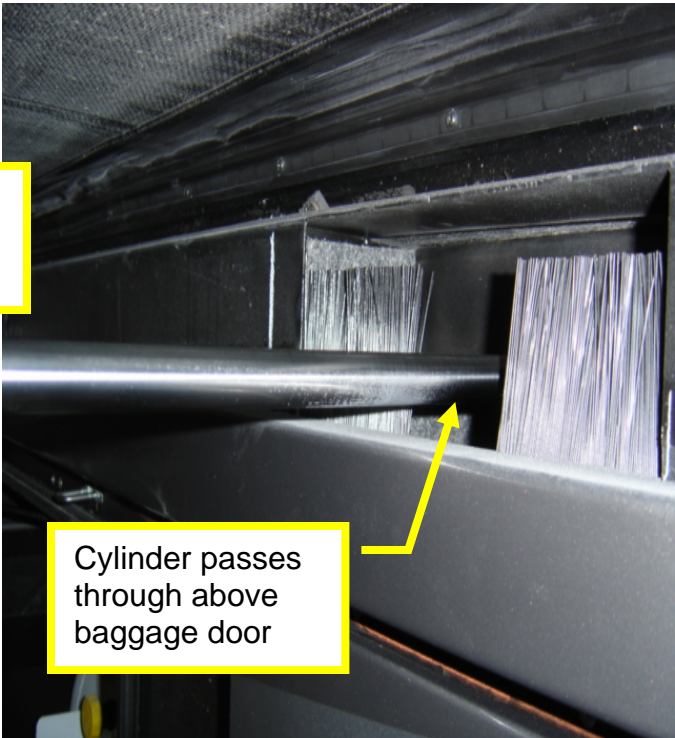

Cylinder passes through above baggage door



Rear (base end) Cylinder attachment



Room Cylinder Clearance Issues- Flat Floor Systems:

- Rear (base end) of cylinder mounted too low
 - Typically, best results are achieved when the center of the cylinders base end threaded rod is $\frac{3}{4}$ " below the bottom of the floor (roof of baggage compartment). Stated another way, the outer diameter of the flat washer is nearly in contact with the bottom of the floor.

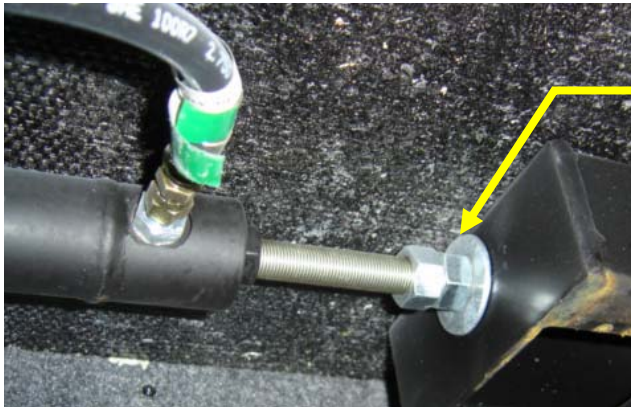

Washer nearly touching bottom of floor

- Nylon "brush" sweep, that finishes the cutout, mounted in a manner that interferes with cylinder rod.

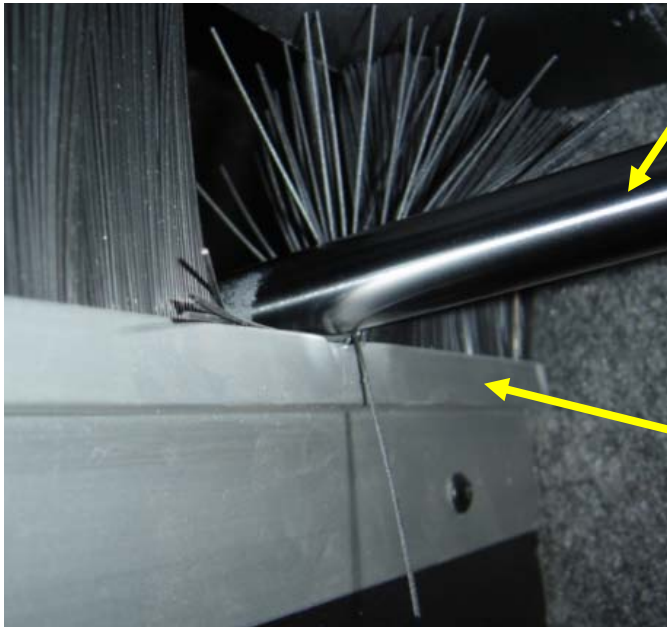

Room
Cylinder
Rod

Nylon Sweep

- Cylinder stroke not set to match distance of room travel
 - This results in the cylinder “bowing” when the room is fully extended. This bowed rod can contact the timing shaft or the cutout resulting in severe damage.

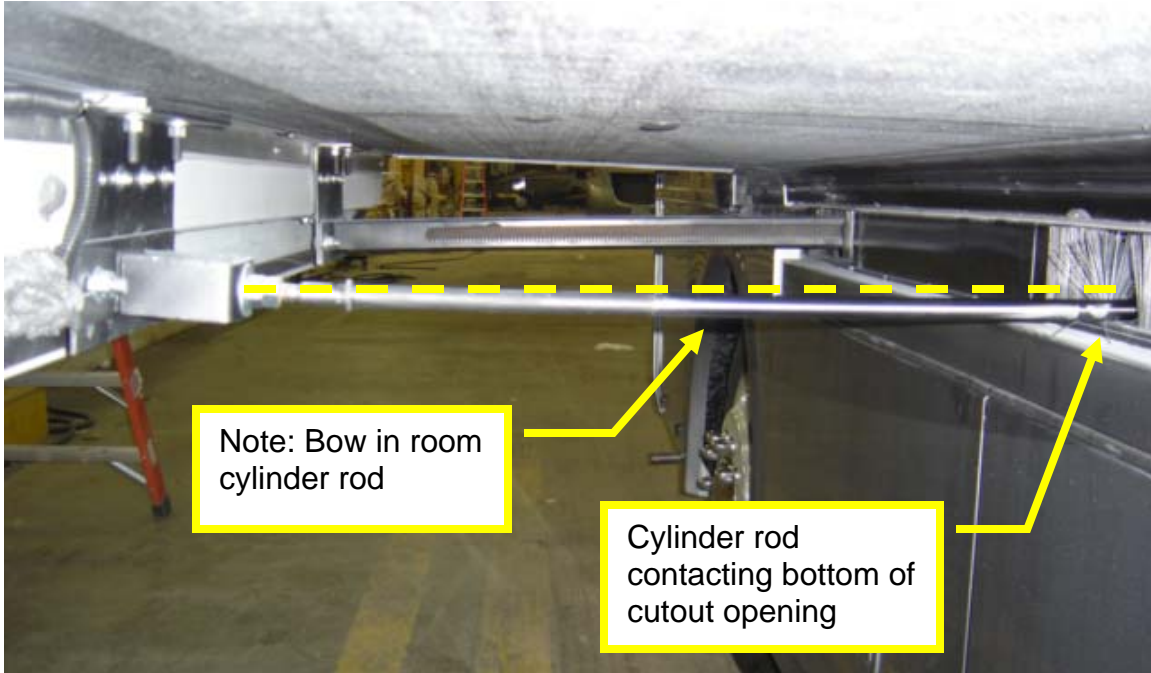

- To eliminate the bow in the cylinder rod, adjust the rod end jamb nuts so that the cylinder is fully extended at the same time the slide room is fully extended.

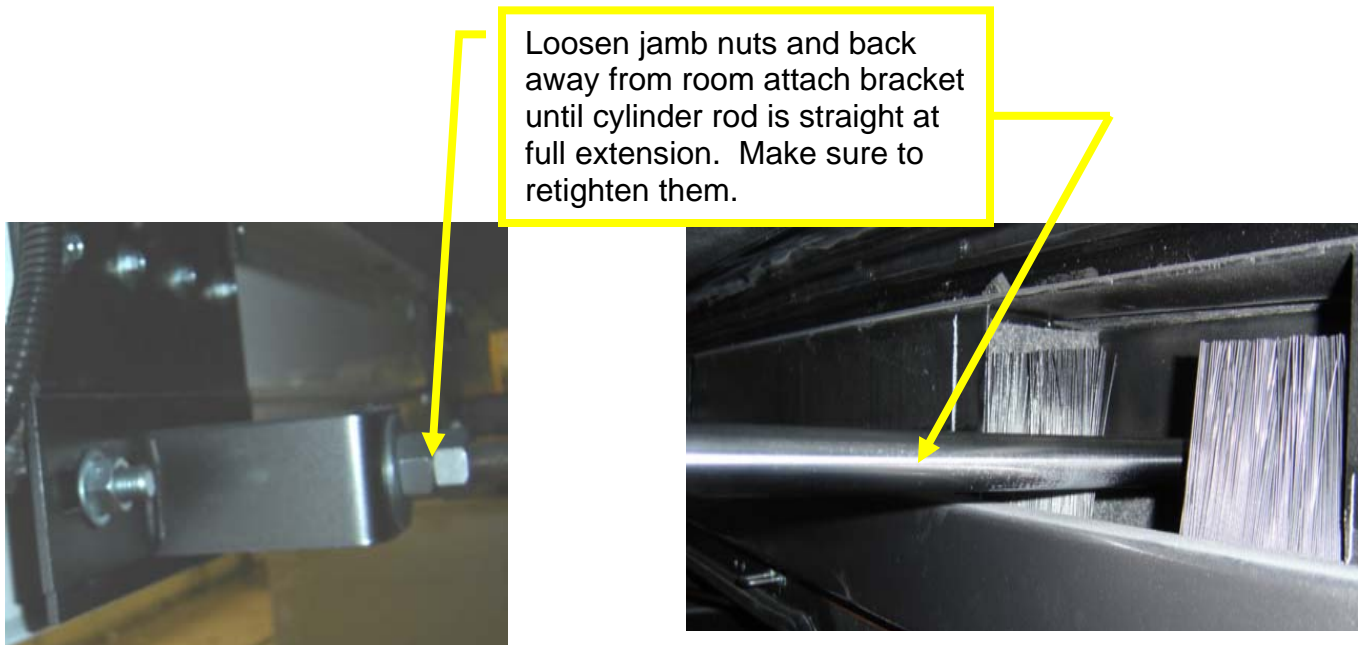

When making this adjustment, note that changes to the length of the cylinder extension have an effect on cylinder retraction. This means that the room could possibly be over-retracted and consequently damage the flanges. It may be necessary to make an additional adjustment at the rear of the cylinder. The goal of these adjustments is to set the cylinder so that it is fully extended when the room is fully extended and fully retracted when the room is fully retracted.



Rear Cylinder Adjustment

Additionally, it may be necessary to leave a space between the two sets of jamb nuts on the room attachment bracket.

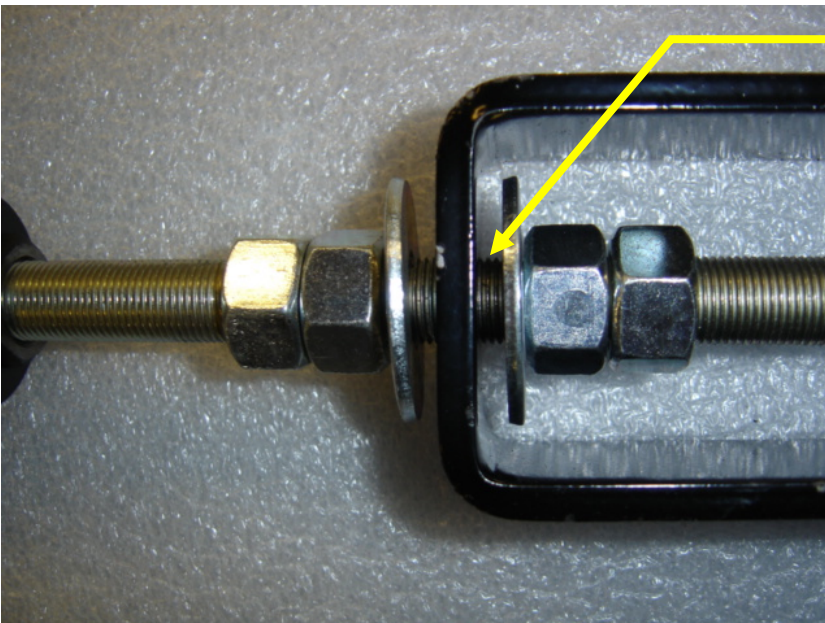

Space between jamb nuts on room attachment bracket

- Cylinder rod to room bracket (bracket that attaches cylinder rod to slide box) mounted too high
 - Best results are usually achieved when this bracket is mounted as low as possible, but still allowed to recess into belt-rail of the coach.

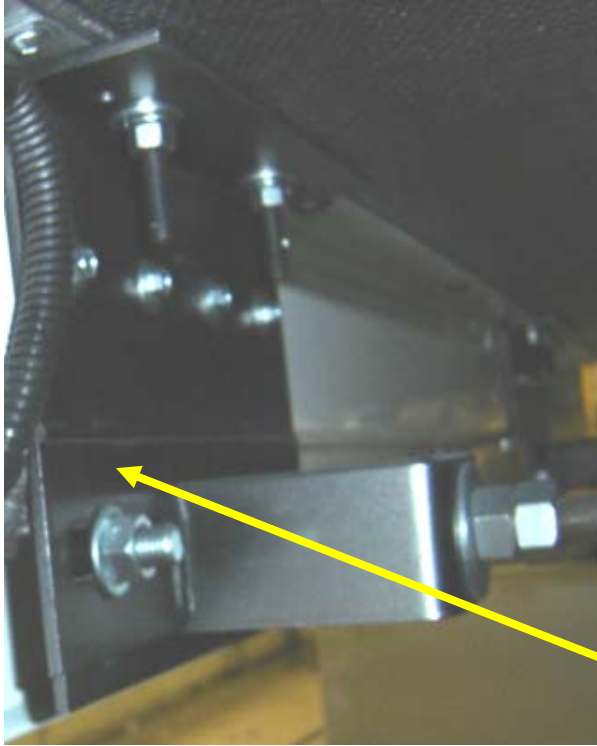

Bracket is mounted with overhanging flange to the TOP

Flange oriented Upward (correct)

Cylinder Connection

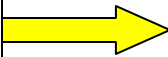

Installation of Cylinder Rod Guard (p/n 2778) - Flat / Flush floor only

The cylinder rod guard can be added to flat floor systems. It is used to physically prevent the cylinder rod from contacting the timing shaft. ***It is not intended to be used as a substitute for proper component placement and adjustment.***
Note: This guard is ONLY used in center drive flat floor applications.

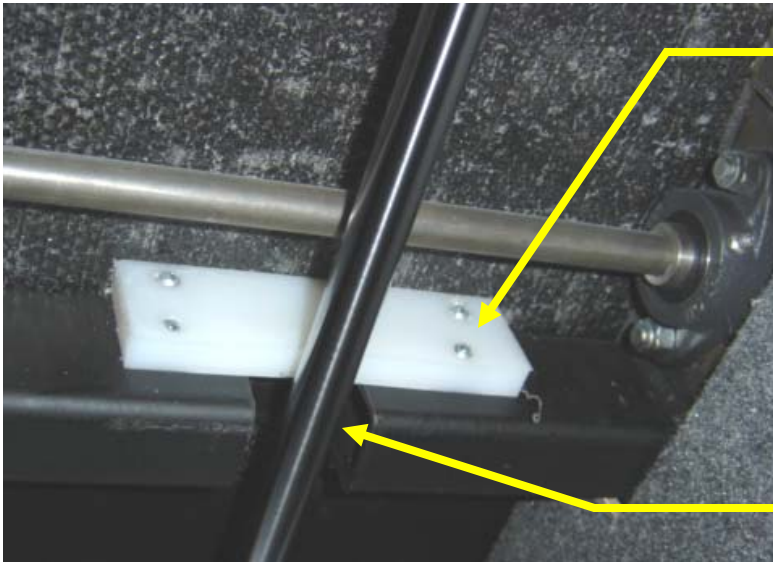

2778- Cylinder Rod Guard
Made of UHMW Nylon
Mounted to slide
mechanism frame with
self-tapping screws.

2778-Centered
over notch in slide
mechanism frame



Installation of Inner Rail Pads - Non Flat Floor (kitchen slide-out) ONLY

Inner rail pads can be added to kitchen slide-outs to help prevent the inner rail from lifting as the room cycles. These pads are placed above the inner rails, attached with screws to the laminate floor structure. Pads are supplied in two sizes and are positioned at the end of the outer tube above the inner rail. They are to be inserted after the slide-out rail heights are properly adjusted (see page 2) and when the system is fully retracted.

- 1) Ensure proper rail height setting
- 2) Fully retract slide-out
- 3) Position rail pad(s) above the inner rail at the end of the outer tube. Two sizes are available .187" and .25". Insert the largest size that can be inserted between the inner tube and the floor without forcing. Two pads may be stacked to take up additional space.
- 4) Position the blocks as shown in the photos below and attach with self-tapping screws.



Insert UHMW strip from side opposite cylinder. Do not allow overlap on cylinder side.

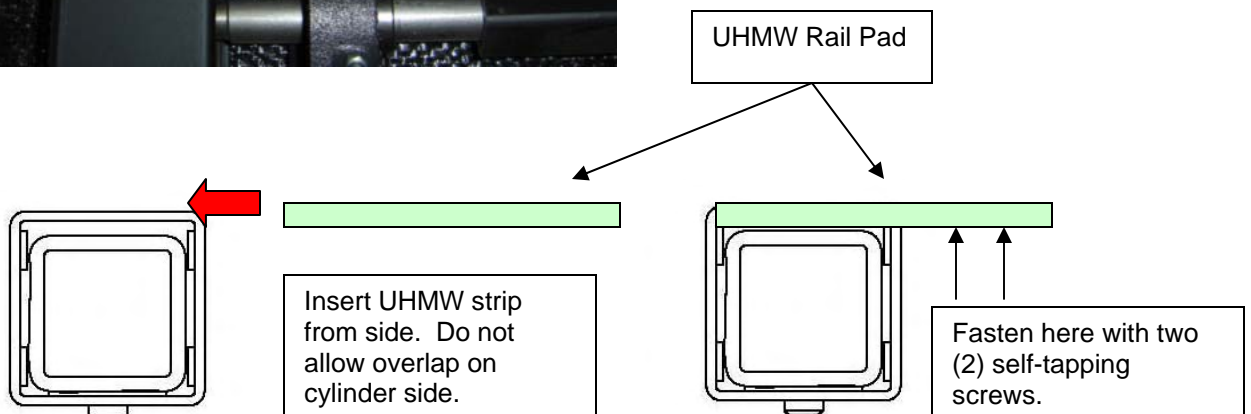

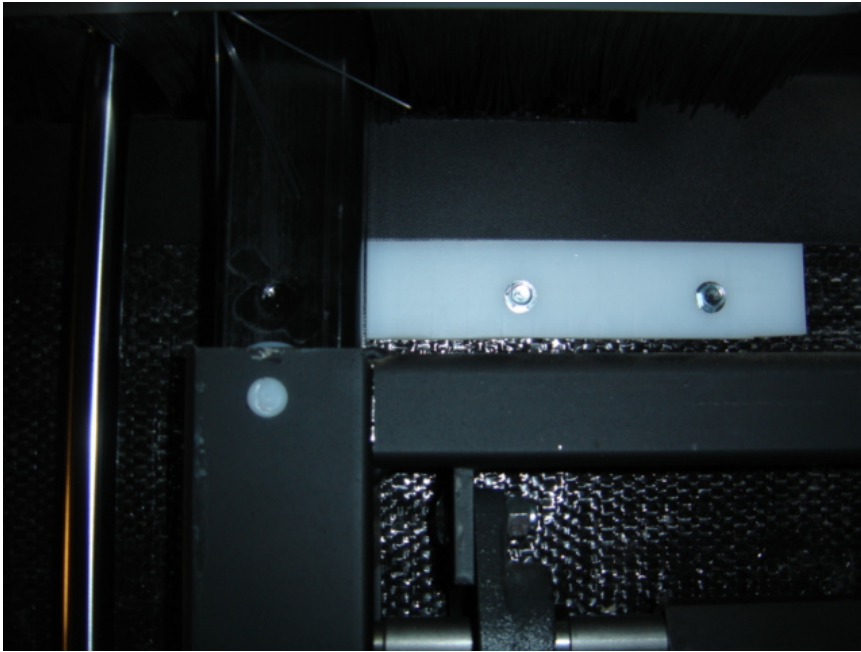

Note: Pad flush with edge of outer rail: cylinder side.

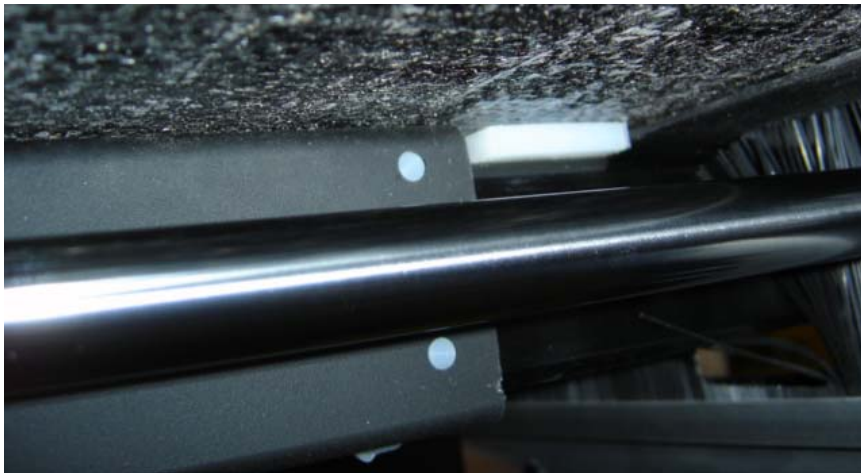

Timing Shaft Replacement

When it is necessary to replace a timing shaft, this task must be performed with the room almost fully retracted. There are cutouts in the outer and inner tubes of the slide rail assembly. These cutouts allow the gear to be removed and are in alignment when the slide is almost fully retracted.

- Position the slide-out to line up the gear removal cutouts.
- Disconnect the timing coupler in the center of the two shafts.
- Loosen the setscrews on the shaft collars or bearings (depending on model).
- Remove the bolts from the bearings.
- Remove the shafts from the coach.
- Examine inner rail gear racks for damage. Remove any debris.
- Install new components in reverse order.
- The center bearing(s) mounting bolts should be tightened first. Position the shafts so the outer diameter of the timing coupler is almost in contact with the bottom of the unit floor (ceiling of baggage compartment).
- After the center bearings are tight, pull down gently on the shaft to make sure the gear is fully engaged in the gear rack and tighten the bearing. Do not pull down to hard as this can cause the gear to bind in the rack. Conversely, if too loose, it can skip and bind. Make all adjustments to gear engagement with the slide-out nearly fully retracted (gears positioned at the gear removal cutouts).
- Make sure that the gear is lined up properly (centered) with the gear rack, and tighten one of the shaft collars or setscrews in one of the middle bearings.
- Adjust the room timing and tighten the timing coupler.
- Tighten all shaft collar or bearing setscrews (optional). Typically, only the setscrews on the middle bearing(s) are tightened.

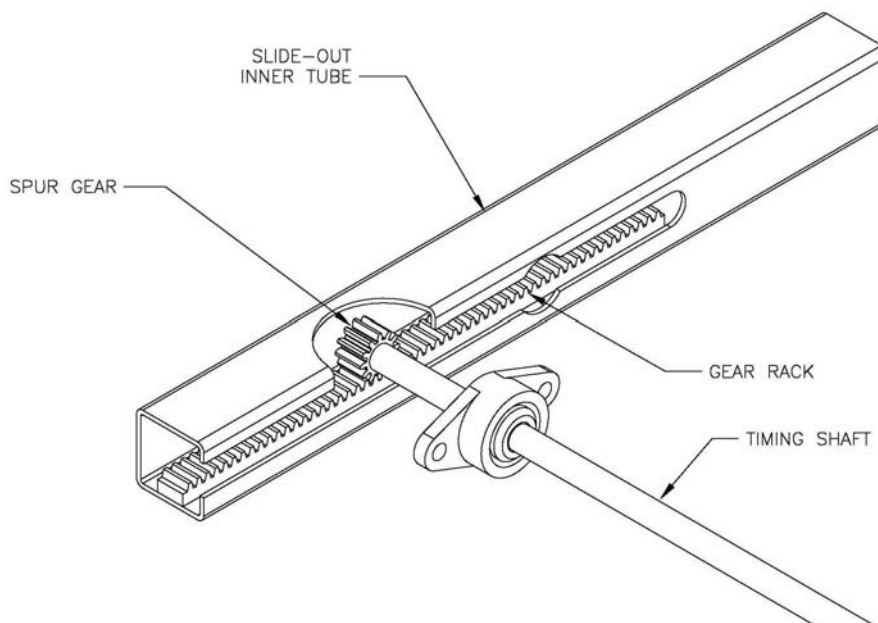

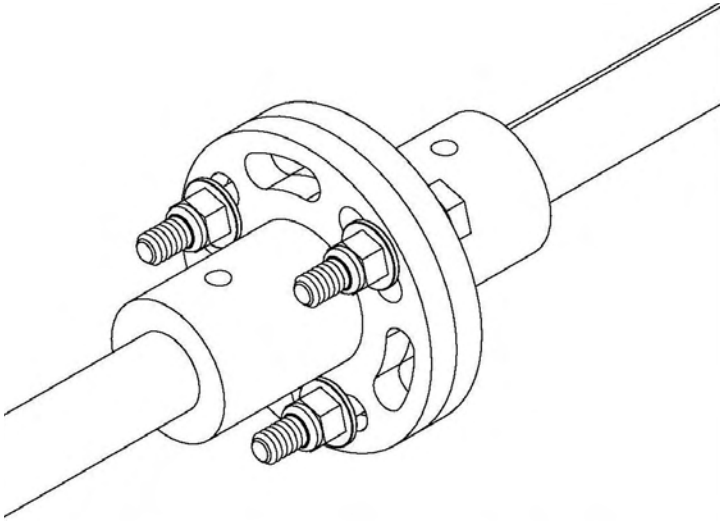

TIMING ADJUSTMENT PROCEDURE

- 1) LOOSEN THE THREE $\frac{1}{4}$ " NUTS ON THE COUPLING.
- 2) SQUARE THE ROOM BY PHYSICALLY MANIPULATING IT. (NOTE: IT MAY BE NECESSARY TO REMOVE THE BOLTS TO GET THE ROOM SQUARE)
- 3) TIGHTEN THE NUTS

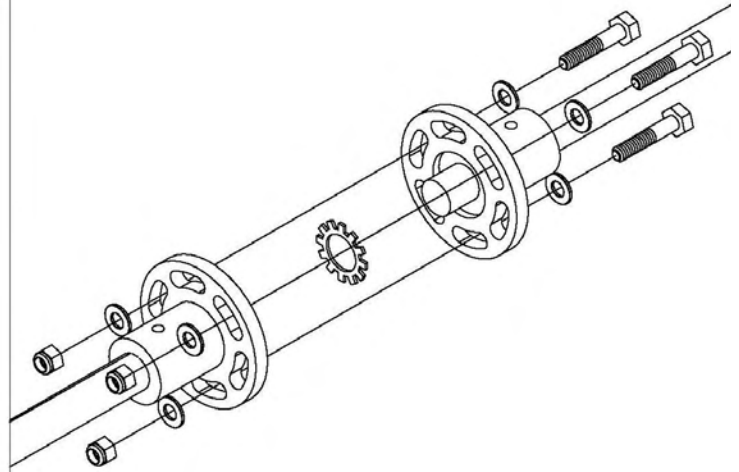

EXPLODED VIEW OF COUPLING

The slide-out mechanisms are designed to operate without added lubrication. Greases and oils can trap and collect dirt that can lead to premature wear. If desired, a coating of WD40 or silicon spray can be applied to the mechanism to prevent rust. Wipe off any excess.

**If you have any questions, please call Equalizer Systems at
(800) 846-9659
Please obtain prior authorization for warranty service or repair.**